



CITY OF WILDOMAR
OFFICIAL PLANNING DIRECTOR HEARING MINUTES
FOR THE SPECIAL MEETING OF JULY 12, 2018

CALL TO ORDER:

The Planning Director's Hearing was called to order by Planning Director, Matthew Bassi at 2:00 P.M. at the Wildomar City Hall, Council Chambers.

Staff Present: Matthew Bassi, Planning Director
Robert Kain, Senior Planner
Alfredo Garcia, Assistant Planner
Dan York, Assistant City Manager/Public Works Director

PUBLIC COMMENTS:

There were no public comments.

1.0 CONSENT CALENDAR:

1.1 Planning Director Hearing Meeting Minutes – October 31, 2017:

RECOMMENDATION: Staff recommends the Planning Director approve the October 31, 2017 Planning Director hearing minutes as submitted.

Action: Planning Director Bassi approved the October 31, 2017 Director hearing minutes as presented.

2.0 PUBLIC HEARING ITEMS:

2.1 Tentative Parcel Map No. 37523 (PA No. 18-0068):

Planning Director consideration of the adoption of a CEQA determination and review of a Schedule H Tentative Parcel Map (TPM No. 37523) to subdivide 25.72 acres into two (2) parcels for finance purposes and future single family and multi-family residential development within the approved Baxter Village Mixed-Use project area located at the NEC of the Baxter Road and White Street (APN: 367-180-015).

Senior Planner Robert Kain made a brief presentation regarding the parcel map.

Director Bassi opened the public hearing and asked for public comments.

Frank Igo, Applicant Representative, was present for the project presentation.

No other public comments were provided.

Director Bassi asked the applicant if he agreed with the conditions of approval.

Frank Igo, Applicant Representative, responded in the affirmative.

With no further discussion, Director Bassi closed the public hearing and adopted DH Resolution No. 2018-01 entitled:

DH RESOLUTION NO. 2018-01

A RESOLUTION OF THE PLANNING DIRECTOR OF THE CITY OF WILDOMAR, CALIFORNIA, APPROVING TENTATIVE PARCEL MAP NO. 37523 (PLANNING APPLICATION NO. 18-0068) TO SUBDIVIDE 25.72 ACRES INTO TWO (2) PARCELS FOR FINANCE PURPOSES, SUBJECT TO CONDITIONS, LOCATED AT THE NORTHEAST CORNER OF BAXTER ROAD AND WHITE STREET (APN: 367-180-015), AND A DETERMINATION THAT ADDITIONAL ENVIRONMENTAL REVIEW IS NOT REQUIRED PER CEQA GUIDELINES SECTION 15162

PLANNING DIRECTOR COMMUNICATIONS

There were no Planning Director Communications.

FUTURE AGENDA ITEMS

None.

ADJOURNMENT

Director Bassi adjourned the July 12, 2018 Director Hearing meeting at 2:08 P.M.



Matthew C. Bassi,
Planning Director/Minutes Secretary

2.0 PUBLIC HEARINGS

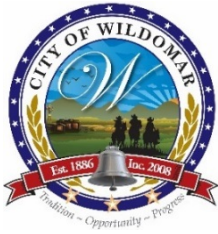

CITY OF WILDOMAR – PLANNING DIRECTOR
Agenda Item #2.1
PUBLIC HEARING
Meeting Date: July 23, 2019

TO: Matthew C. Bassi, Planning Director

FROM: Robert Kain, Senior Planner

SUBJECT: **Tentative Parcel Map No. 37717 (PA No. 19-0068):**
Planning Director consideration of a CEQA Exemption and review of a “Schedule H” Tentative Parcel Map (TPM No. 37717) to subdivide 30.74 acres into three (3) parcels.

STAFF REPORT

RECOMMENDATION:

The Planning Department recommends the Planning Director take the following action:

1. Adopt a Resolution entitled:

DH RESOLUTION NO. 2019-01

A RESOLUTION OF THE PLANNING DIRECTOR OF THE CITY OF WILDOMAR, CALIFORNIA, ADOPTING A CATEGORICAL EXEMPTION IN ACCORDANCE WITH SECTION 15315 OF CEQA AND APPROVING TENTATIVE PARCEL MAP NO. 37717 (PLANNING APPLICATION NO. 19-0068), SUBJECT TO CONDITIONS TO SUBDIVIDE 30.74 ACRES INTO THREE (3) PARCELS LOCATED AT THE SOUTHEAST CORNER OF PALOMAR STREET AND SOUTH PASADENA STREET (APN: 380-050-001, 002, 005 & 006)

PROJECT DESCRIPTION:

The Applicant has proposed a Schedule H Tentative Parcel Map (TPM No. 37717) to subdivide 30.74 acres into three (3) parcels. The Anne Sullivan Nursery School will remain on parcel 3; the CAFH Oder of Wildomar will retain ownership of Parcels 1 and 2. There is no proposed development with this parcel map at this time.

Project Location:

The proposed project is located at the SEC of the Palomar Street and South Pasadena Street (APN: 380-050-001, 002, 005 & 006). The project site encompasses approximately 30.74 acres. The vicinity/location map on the following page shows the project site and surrounding area.

Vicinity/Location Map



Surrounding Land Uses:

The southern end of the project site is currently developed with the northerly portion remaining vacant. The project site is surrounded by residential lands to the north, south, east, and west. Table 1 on the following page summarizes the current uses, land use and zoning designations related to the project site and surrounding properties. The exhibits on the following pages illustrate the land uses and zoning of the subject site and surrounding areas.

Table 1 - General Plan Land Use and Zoning Designations

ADJACENT LAND USE, GENERAL PLAN AND ZONING			
Location	Current Land Use	General Plan Land Use Designation	Zoning Designation
Subject Property	Existing Residential/Nursery School	Medium Density Residential (MDR)	R-R (Rural Residential)
North	Existing Residential	Medium Density Residential (MDR)	R-R (Rural Residential)
South	Existing Residential	Medium Density Residential (MDR)	R-R (Rural Residential)
East	Existing Residential	Medium Density Residential (MDR)	R-R (Rural Residential)
West	Existing Residential	Medium Density Residential (MDR) Very High Density Residential (VHDR)	R-R (Rural Residential) and R-3 (General Residential)

General Plan Existing Land Use Exhibit

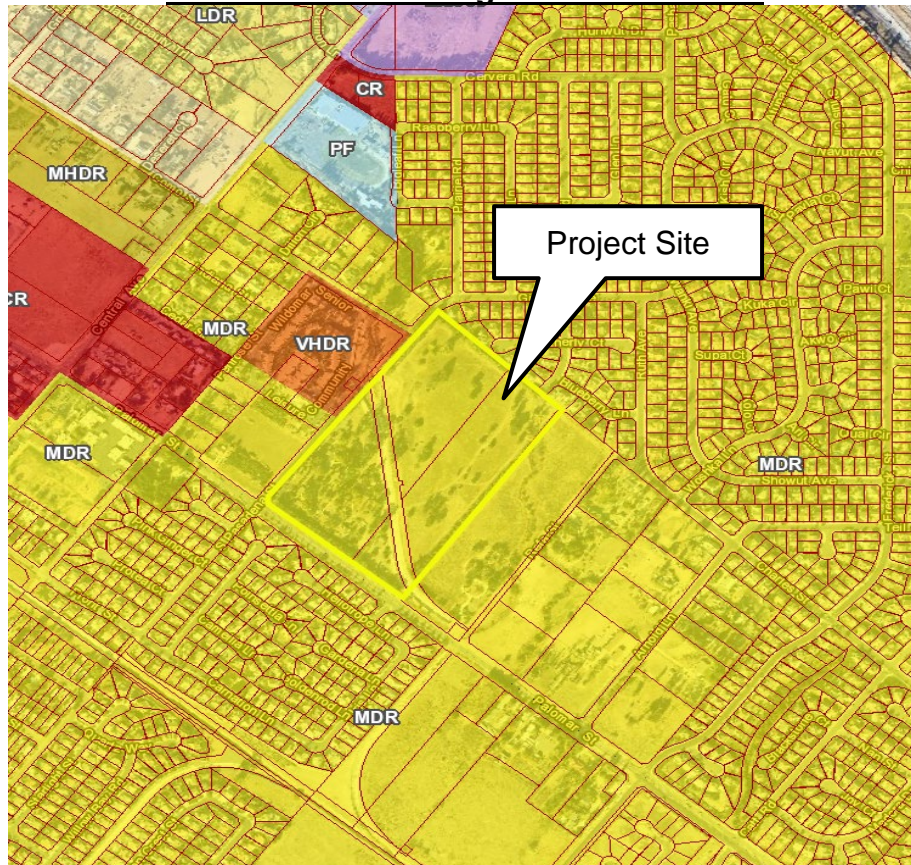

Zoning Designation Exhibit



CEQA Determination:

In accordance with the California Environmental Quality Act (CEQA) Guidelines, the Planning Department has evaluated the proposed project to determine what level of CEQA review is required. Based on this evaluation, staff has determined that the proposed parcel map meets the findings for a Categorical Exemption in accordance with Section 15315 (Minor Land Divisions – Class 15) of CEQA. See analysis section below for additional information.

Tentative Parcel Map No. 37717:

The applicant is proposing Tentative Parcel Map Parcel Map No. 37717 to subdivide 30.74 acres into three (3) parcels. A reduced exhibit of the parcel map is shown below. The proposed Parcel Map is required to meet minimum R-R (Rural Residential) zone development standards as outlined in Section 17.16 related to lot size and lot depth/width.

Parcel Map No. 37717 Exhibit

TENTATIVE PARCEL MAP NO. 37717

IN THE CITY OF WILDOMAR, COUNTY OF RIVERSIDE, STATE OF CALIFORNIA

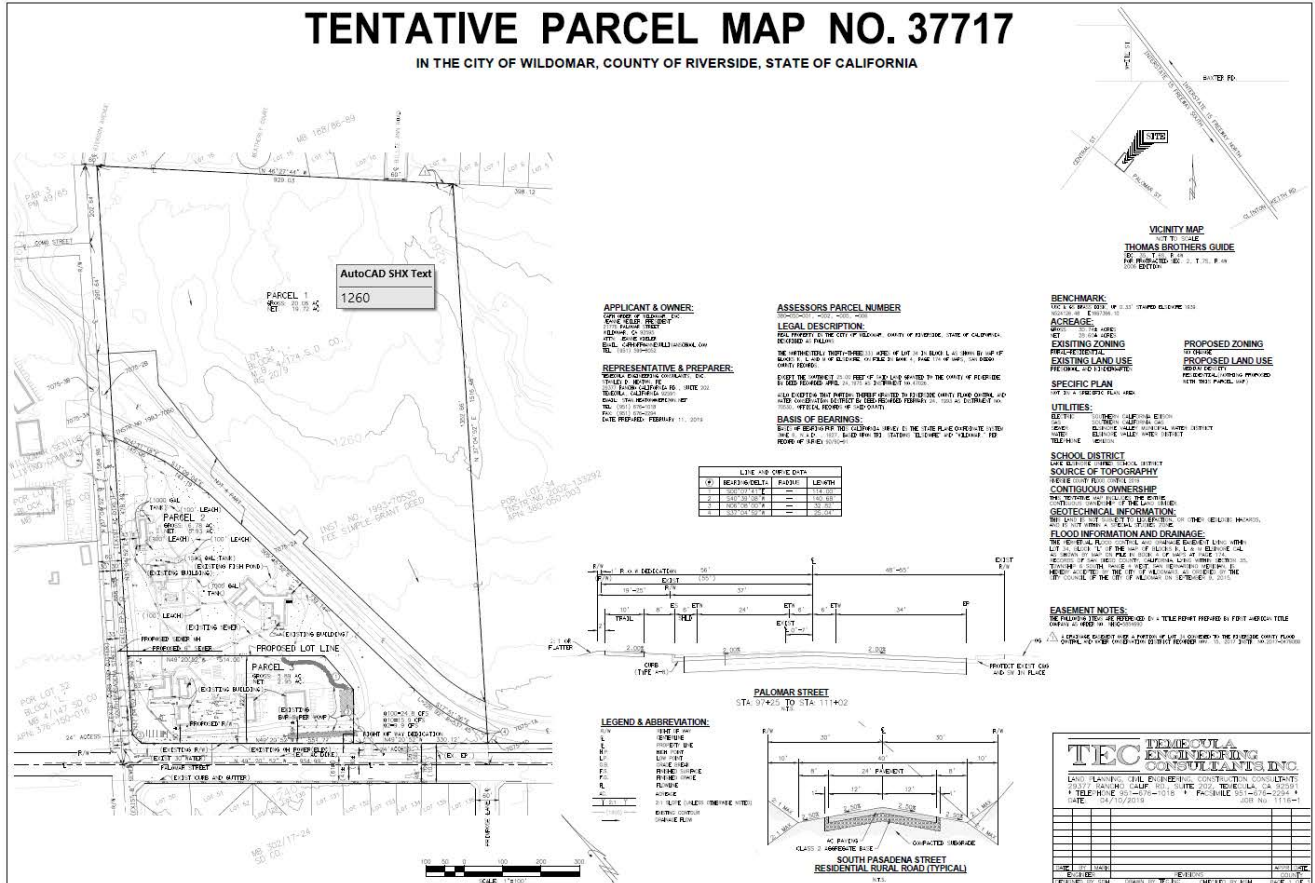

Proposed Lot Sizes:

The proposed lot sizes range in size from 3.89 to 20.06 acres. Parcel 1 will be 20.06 acres; Parcel 2 will be 6.78 and parcel 3 will be 3.89 acres. Depending on future uses, each parcel may require an additional plot plan or conditional use permit as outlined in the R-R zone. A summary table of the lot sizes is shown below. In terms of lot size and depth, the parcel map exceeds the minimum development standards for the R-R zone.

Table 2 - Parcel Map No. 37717 – Development Standard Table

PARCEL	MINIMUM LOT SIZE	PROPOSED LOT SIZE (ACRES)	MINIMUM LOT WIDTH	PROPOSED LOT WIDTH	MINIMUM LOT DEPTH	PROPOSED LOT DEPTH	EXCEEDS MINIMUM STANDARDS
1	.50 Acres	20.06	80 ft.	1,300+ ft.	100 ft.	900+ ft.	Yes
2	.50 Acres	6.78	80 ft.	800+ ft.	100 ft.	450+ ft.	Yes
3	.50 Acres	3.89	80 ft.	500+ ft.	100 ft.	200+ ft.	Yes

Vehicular Access/Streets:

Access to parcels 1 & 2 will be provided via South Pasadena and access to parcel 3 will be provided via South Pasadena on the westerly end of the property and via Palomar Street on the easterly end of the parcel

PROJECT ANALYSIS / FINDINGS OF FACT:

CEQA Analysis:

In accordance with the California Environmental Quality Act (CEQA) Guidelines, the Planning Department evaluated the proposed Parcel Map to determine what level of CEQA environmental review is required. Based on this review, the Planning Department has determined that approval of the proposed Parcel Map meets the findings for a Categorical Exemption in accordance with Section 15315 (Minor Land Divisions – Class 15) of CEQA. Class 15 consists of the division of property in urbanized areas zoned for residential, commercial, or industrial use into four or fewer parcels when the division is: 1) in conformance with the General Plan and Zoning; 2) no variances or exceptions are required; 3) all public services and access to the proposed parcels are available; 4) the parcel was not involved in a division of a larger parcel within the previous 2 years; and 5) the parcel does not have an average slope greater than 20 percent. The project meets these findings in that: 1) the parcel map is in conformance with General Plan and Zoning as demonstrated by compliance with the land use and zoning standards; 2) there are no variances or exceptions are required for the parcel map; 3) the parcel is available for all public services and contains legal access to the site; 4) the parcel has not involved in a division of a larger parcel within the previous 2 years; and 5) the average slope of the parcel is less than the 20% maximum allowed by code. Therefore, based on these factors, staff recommends the Planning Director adopt a Categorical Exemption in accordance with Section 15315 (Minor Land Divisions – Class 15) of CEQA.

Tentative Parcel Map No. 37717:

The proposed Parcel Map is required to meet minimum development standards outlined in Section 17.16.020 of the R-R zone related to lot size and depth/width. A summary of the 3-lot parcel map is provided in Table 2 above. In terms of lot size and depth, the parcel map exceeds the minimum development standards of the R-R zone. Based on the proposed parcel map design, all lots meet and or exceed the minimum standards as discussed in the project description section of the staff report. The project as proposed and conditioned is also consistent with the General Plan.

Tentative Parcel Map No. 37717 Findings of Fact:

In accordance with Wildomar Municipal Code Title 16 and Title 17, and Government Code § 66473.1, § 66473.5 and § 66474, staff recommends the Planning Director, in light of the whole record before it, including but not limited to the Planning Department's staff report and all documents incorporated by reference therein, the City's General Plan, Subdivision Ordinance, Zoning Ordinance, and any other evidence within the record or provided at the public hearing of this matter, find and determine as follows:

- A. The proposed Parcel map is consistent with the City's General Plan and any applicable specific plan as specified in Government Code Section 65451.

Evidence: The proposed Tentative Parcel Map No. 37717 is consistent with the City's General Plan in that the land use designations of Medium Density Residential (MDR) which are intended to provide for the development of detached single family residences and ancillary structures on large parcels of land that are at least .5 acre in size. The project proposes to divide a 30.74-acre parcel into 3 parcels that will be 3.89 to 20.06 acres in size. Therefore, the parcel map meets the General Plan minimum density requirement of 1 unit/acre. Further, the parcel map and land use is consistent with the surrounding land use designations. Additionally, there is no specific plan governing the proposed project site. The project also promotes the following general plan policies:

- LU 2.1 The proposed project will accommodate a land use development that is in accordance with patterns and distribution of land uses that are depicted on the General Plan Land Use map proposed for the subject site.
- LU 4.1 The proposed project will accommodate a land use development proposal that is located and designed to visually enhance and not degrade the character of the surrounding area.
- LU 22.1 Accommodate the development of single residential units in areas appropriately designated by the General Plan and area plan land use maps.
- LU 22.10 Require that residential units/projects be designed to consider their surroundings and to visually enhance, not degrade, the character of the immediate area.

- B. The design or improvement of the proposed subdivision is consistent with the City's General Plan and any applicable specific plan.

Evidence: The proposed subdivision has been designed to meet all City standards applicable to residential subdivisions which are designed to provide satisfactory pedestrian and vehicular circulation, including emergency vehicle access and on-site and off-site public improvements. Further, all streets, utilities, and drainage facilities have been designed and are required to be constructed in conformance with City standards and the County of Riverside Fire Department standards. In addition, there is no specific plan governing this project.

- C. The site is physically suitable for the type and proposed density of development.

Evidence: The project site encompasses approximately 30.74 acres. The tentative parcel map proposes to divide the project area into 3 parcels for estate purposes. No changes to the existing residences and nursery school are proposed as part of

this approval. No future development plans are under consideration at this time. The R-R zone requires a one half-acre minimum lot size with a minimum average lot width of 80-feet and a lot depth of 100-feet. The proposed project meets and exceeds these minimum requirements, thus, the site being physically suitable.

- D. The design of the subdivision or proposed improvements are not likely to cause substantial environmental damage or substantially and avoidably injure fish or wildlife or their habitat.

Evidence: The proposed project meets the findings for a Categorical Exemption in accordance with Section 15315 (Minor Land Divisions – Class 15) of CEQA consisting of the division of property in an urbanized area zoned for residential development. Additionally, the design of the subdivision is in conformance with the requirements outlined in the General Plan and Zoning Code in terms of minimum lot size requirements. Thus, it has been determined that the design of the subdivision will not likely cause environmental damage or substantially and avoidably injure fish or wildlife or their habitat project. Therefore, the proposed Parcel Map meets this finding.

- E. The design of the subdivision or type of improvements is not likely to cause serious public health problems.

Evidence: The design of the subdivision is in conformance with the City's General Plan and Zoning Code. The design of all applicable improvements to accommodate the project have been conditioned to in accordance with all applicable City of Wildomar ordinances, codes, and standards including, but not limited to, the California Uniform Building Code, the City's Ordinances relating to storm water runoff management and adopted public works standards. As the City's ordinances, codes, and standards have been created based on currently accepted standards and practices for the preservation of the public health, safety and welfare, the proposed Parcel Map project meets this finding.

- F. The design of the subdivision or the type of improvements will not conflict with easements, acquired by the public at large, for access through or use of, property within the proposed subdivision.

Evidence: No easements of record or easements established by judgment of a court of competent jurisdiction for public access across the site have been disclosed in a search of the title records for the site and the City does not otherwise have any constructive or actual knowledge of any such easements.

PUBLIC NOTICING/COMMUNICATION:

In accordance with Section 16.12.140 of the Wildomar Municipal Code, the City of Wildomar Planning Department, on July 9, 2019 mailed a public hearing notice to all property owners within a 600-foot radius of the project boundaries notifying said property owners of the date and time of the July 23, 2019 Director hearing for which Tentative

Parcel Map No. 37717 would be considered by the Planning Director. In accordance with Section 16.12.140 of the Wildomar Municipal Code, the City of Wildomar Planning Department, on July 12, 2019 published a legal notice in the "Press Enterprise", a local newspaper of general circulation, in compliance with State law notifying the general public of the date and time of the July 23, 2019 Director hearing for which Tentative Parcel Map No. 37717 would be considered by the Planning Director. Further, in accordance with Ordinance No. 135, the Planning Department on July 12, 2019 posted two (2) public hearing notice "sign board" at the project site (on South Pasadena and Palomar Road) identifying hearing information for area residents regarding the July 23, 2018 Director hearing for which Tentative Parcel Map No. 37717 would be considered by the Planning Director.

Respectfully Submitted,
Robert Kain
Senior Planner

Reviewed By,
Mark Teague
Assistant Planning Director

ATTACHMENTS:

- A. DH Resolution No. 2019-01 for Tentative Parcel Map No. 37717
Exhibit 1 - Conditions of Approval Matrix
- B. Tentative Parcel Map No. 37717 Subdivision Map Exhibit

INCORPORATED HEREIN BY REFERENCE THE FOLLOWING:

- City of Wildomar General Plan and General Plan EIR
- City of Wildomar Subdivision Ordinance (Title 16 of the WMC)
- City of Wildomar Zoning Ordinance (Title 17 of the WMC)

ATTACHMENT A

DH Resolution No. 2019-01

DH RESOLUTION NO. 2019-01

A RESOLUTION OF THE PLANNING DIRECTOR OF THE CITY OF WILDOMAR, CALIFORNIA, ADOPTING A CATEGORICAL EXEMPTION IN ACCORDANCE WITH SECTION 15315 OF CEQA AND APPROVING TENTATIVE PARCEL MAP NO. 37717 (PLANNING APPLICATION NO. 19-0068), SUBJECT TO CONDITIONS TO SUBDIVIDE 30.74 ACRES INTO THREE (3) PARCELS LOCATED AT THE SOUTHEAST CORNER OF PALOMAR STREET AND SOUTH PASADENA STREET (APN: 380-050-001, 002, 005 & 006)

WHEREAS, an application for Tentative Parcel Map No. 37717 to subdivide 30.74 acres into 3 parcels purposes has been filed by:

Applicant / Owner:	CAFH Order of Wildomar
Project Location:	Southeast corner of South Pasadena Street and Palomar Street
APN Number:	380-050-001, 002, 005 & 006
Lot Area:	30.74 acres

WHEREAS, in accordance with the California Government Code Section 66452 – 66452.22 (Subdivision Map Act), the City of Wildomar Subdivision Ordinance (Title 16), the Planning Director of the City of Wildomar, California, has the authority and has reviewed the proposed Tentative Parcel Map No. 37717; and

WHEREAS, in accordance with Government Code Section 66452.3, the City has provided the applicant with a copy of the Planning Department staff report and resolutions for Tentative Parcel Map No. 37717 containing staff’s recommendation to the Planning Director at least three (3) days prior to the below referenced noticed public hearing; and

WHEREAS, the proposed Tentative Parcel Map No. 37717 is considered a “Project” as defined by the California Environmental Quality Act, Public Resources Code §21000 et seq. (“CEQA”); and

WHEREAS, the proposed Tentative Parcel Map application is considered Categorically Exempt as defined by Section 15315 (Minor Land Divisions – Class 15) of the California Environmental Quality Act, Public Resources Code § 21000 et seq. (“CEQA”); and

WHEREAS, in accordance with Section 16.12.140 of the Wildomar Municipal Code, the City of Wildomar Planning Department, on July 9, 2019 mailed a public hearing notice to all property owners within a 600-foot radius of the project boundaries notifying said property owners of the date and time of the public hearing for which the Tentative Parcel Map No. 37717 would be considered by the Planning Director; and

WHEREAS, in accordance with Ordinance No. 135, the Planning Department on July 12, 2018 posted one (1) public hearing notice sign board at the subject site notifying the general public and area residents of the date and time of the July 23, 2019 Planning Director meeting for Tentative Parcel Map No. 37717; and

WHEREAS, in accordance with Section 16.12.140 of the Wildomar Municipal Code, the City of Wildomar Planning Department, on July 12, 2019 published a legal notice in the “Press Enterprise”, a local newspaper of general circulation, in compliance with State law notifying the general public of the public hearing for which Tentative Parcel Map No. 37523 would be considered by the Planning Director; and

WHEREAS, in accordance with Section 16.12.140 of the Wildomar Municipal Code, the Planning Director on July 23, 2019 held said public hearing at which time the Planning Director received public testimony from interested persons in support of, or opposition to, the proposed Tentative Parcel Map No. 37717.

NOW THEREFORE, the Planning Director of the City of Wildomar does hereby resolve, determine, order as follows:

SECTION 1. CEQA FINDINGS

In accordance with the California Environmental Quality Act (CEQA) Guidelines, the Planning Department evaluated the proposed Parcel Map to determine what level of CEQA environmental review is required. Based on this review, the Planning Department has determined that approval of the proposed Parcel Map meets the findings for a Categorical Exemption in accordance with Section 15315 (Minor Land Divisions – Class 15) of CEQA. Class 15 consists of the division of property in urbanized areas zoned for residential, commercial, or industrial use into four or fewer parcels when the division is 1) in conformance with the General Plan and Zoning; 2) no variances or exceptions are required; 3) all public services and access to the proposed parcels are available; 4) the parcel was not involved in a division of a larger parcel within the previous 2 years; and 5) the parcel does not have an average slope greater than 20 percent. The project meets these findings in that 1) the parcel map is in conformance with General Plan and Zoning as demonstrated by compliance with the land use and zoning standards; 2) there are no variances or exceptions are required for the parcel map; 3) the parcel is available for all public services and contains legal access to the site; 4) the parcel has not involved in a division of a larger parcel within the previous 2 years; and 5) the average slope of the parcel is less than the 20% maximum allowed by code. Therefore, based on these factors, staff recommends the Planning Director adopt a Categorical Exemption in accordance with Section 15315 (Minor Land Divisions – Class 15) of CEQA.

SECTION 2 TENTATIVE PARCEL MAP NO. 37717 FINDINGS

In accordance with Wildomar Municipal Code Title 16 and Title 17, and Government Code § 66473.1, § 66473.5 and § 66474, the Planning Director, in light of the whole record before it, including but not limited to the Planning Department's staff report and all documents incorporated by reference therein, the City's General Plan, Subdivision Ordinance, Zoning Ordinance, standards for public streets and facilities, and any other evidence within the record or provided at the public hearing of this matter, hereby finds and determines as follows:

- A. The proposed Parcel map is consistent with the City's General Plan and any applicable specific plan as specified in Government Code Section 65451.

Evidence: The proposed Tentative Parcel Map No. 37717 is consistent with the City's General Plan in that the land use designations of Medium Density Residential (MDR) which are intended to provide for the development of detached single family residences and ancillary structures on large parcels of land that are at least .5 acre in size. The project proposes to divide a 30.74-acre parcel into 3 parcels that will be 3.89 to 20.06 acres in size. Therefore, the parcel map meets the General Plan minimum density requirement of 1 unit/acre. Further, the parcel map and land use is consistent with the surrounding land use designations. Additionally, there is no specific plan governing the proposed project site. The project also promotes the following general plan policies:

LU 2.1 The proposed project will accommodate a land use development that is in accordance with patterns and distribution of land uses that are depicted on the General Plan Land Use map proposed for the subject site.

LU 4.1 The proposed project will accommodate a land use development proposal that is located and designed to visually enhance and not degrade the character of the surrounding area.

LU 22.1 Accommodate the development of single residential units in areas appropriately designated by the General Plan and area plan land use maps.

LU 22.10 Require that residential units/projects be designed to consider their surroundings and to visually enhance, not degrade, the character of the immediate area.

- B. The design or improvement of the proposed subdivision is consistent with the City's General Plan and any applicable specific plan.

Evidence: The proposed subdivision has been designed to meet all City standards applicable to residential subdivisions which are designed to provide satisfactory pedestrian and vehicular circulation, including emergency vehicle access and on-site and off-site public improvements. Further, all streets, utilities, and drainage

facilities have been designed and are required to be constructed in conformance with City standards and the County of Riverside Fire Department standards. In addition, there is no specific plan governing this project.

- C. The site is physically suitable for the type and proposed density of development.

Evidence: The project site encompasses approximately 30.74 acres. The tentative parcel map proposes to divide the project area into 3 parcels for estate purposes. No changes to the existing residences and nursery school are proposed as part of this approval. No future development plans are under consideration at this time. The R-R zone requires a one half-acre minimum lot size with a minimum average lot width of 80-feet and a lot depth of 100-feet. The proposed project meets and exceeds these minimum requirements, thus, the site being physically suitable.

- D. The design of the subdivision or proposed improvements are not likely to cause substantial environmental damage or substantially and avoidably injure fish or wildlife or their habitat.

Evidence: The proposed project meets the findings for a Categorical Exemption in accordance with Section 15315 (Minor Land Divisions – Class 15) of CEQA consisting of the division of property in an urbanized area zoned for residential development. Additionally, the design of the subdivision is in conformance with the requirements outlined in the General Plan and Zoning Code in terms of minimum lot size requirements. Thus, it has been determined that the design of the subdivision will not likely cause environmental damage or substantially and avoidably injure fish or wildlife or their habitat project. Therefore, the proposed Parcel Map meets this finding.

- E. The design of the subdivision or type of improvements is not likely to cause serious public health problems.

Evidence: The design of the subdivision is in conformance with the City's General Plan and Zoning Code. The design of all applicable improvements to accommodate the project have been conditioned to in accordance with all applicable City of Wildomar ordinances, codes, and standards including, but not limited to, the California Uniform Building Code, the City's Ordinances relating to storm water runoff management and adopted public works standards. As the City's ordinances, codes, and standards have been created based on currently accepted standards and practices for the preservation of the public health, safety and welfare, the proposed Parcel Map project meets this finding.

- F. The design of the subdivision or the type of improvements will not conflict with easements, acquired by the public at large, for access through or use of, property within the proposed subdivision.

Evidence: No easements of record or easements established by judgment of a court of competent jurisdiction for public access across the site have been disclosed in a search of the title records for the site and the City does not otherwise have any constructive or actual knowledge of any such easements.

SECTION 4. PLANNING DIRECTOR ACTION.

Based on the findings above, the Planning Director hereby approves DH Resolution No. 2019-01 adopting a Categorical Exemption in accordance with Section 15315 of CEQA, and approving Tentative Parcel Map No. 37711 (PA No. 19-0068), subject to conditions as provided herein and attached hereto to this Resolution as Exhibit 1.

PASSED, APPROVED AND ADOPTED this 23rd day of July, 2019.

Matthew C. Bassi
Planning Director/Minutes Secretary

Exhibit 1
Conditions of Approval
For TPM No. 37717

ATTACHMENT A - EXHIBIT 1 CONDITIONS OF APPROVAL			
Project No.: Tentative Parcel Map No. 37717 (Planning Application No. 19-0068)			
Applicant: Ms. Jean Weiler, Ann Sullivan Nursery School - APN: 380-050-001, 002, 005 & 006			
<u>TPM No. 37717 (Dir. Hearing Approval Date):</u> July 23, 2019		<u>TPM No. 37717 (Expiration Date):</u> July 23, 2022	
<u>Conditions of Approval</u>		<u>Timing / Implementation</u>	<u>Enforcement / Monitoring</u>
		<u>Verification (Date and Signature)</u>	

PLANNING DEPARTMENT CONDITIONS			
<u>General Requirements / Standard Conditions</u>			
1.	In compliance with Section 15094 of the CEQA Guidelines, a Notice of Determination (NOD) shall be filed with the Riverside County Clerk within <u>five (5) working days</u> of project approval by the Planning Director. The notice shall include the required Riverside County Clerk administrative fee (paid by the Applicant) in the amount of <u>\$50.00</u> .	July 28, 2019	Planning Department
2.	The Applicant shall review and sign below verifying the "Acceptance of the Conditions of Approval" and return the signed page to the Wildomar Planning Department within two weeks of the City Council approval. <hr style="width: 100%;"/>	August 6, 2019	Planning Department
	Applicant Signature Date		
3.	The Applicant shall indemnify, protect, defend, and hold harmless, the City, and/or any of its officials, officers, employees, agents, departments, agencies, and instrumentalities thereof, from any and all claims, demands, law suits, writs of mandamus, and other actions and proceedings (whether legal, equitable, declaratory, administrative or adjudicatory in nature), and alternative dispute resolutions procedures (including, but not limited to arbitrations, mediations, and other such	Ongoing	Planning Department

**ATTACHMENT A - EXHIBIT 1
CONDITIONS OF APPROVAL**

Project No.: Tentative Parcel Map No. 37717 (Planning Application No. 19-0068)

Applicant: Ms. Jean Weiler, Ann Sullivan Nursery School - APN: 380-050-001, 002, 005 & 006

TPM No. 37717 (Dir. Hearing Approval Date):

July 23, 2019

TPM No. 37717 (Expiration Date:)

July 23, 2022

Conditions of Approval

**Timing /
Implementation**

**Enforcement /
Monitoring**

**Verification (Date
and Signature)**

procedures), (collectively "Actions"), brought against the City, and/or any of its officials, officers, employees, agents, departments, agencies, and instrumentalities thereof, that challenge, attack, or seek to modify, set aside, void, or annul, the any action of, or any permit or approval issued by, the City and/or any of its officials, officers, employees, agents, departments, agencies, and instrumentalities thereof (including actions approved by the voters of the City), for or concerning the project, whether such Actions are brought under the California Environmental Quality Act, the Planning and Zoning Law, the Subdivision Map Act, Code of Civil Procedure Section 1085 or 1094.5, or any other state, federal, or local statute, law, ordinance, rule, regulation, or any decision of a court of competent jurisdiction. City shall promptly notify the Applicant of any Action brought and request that Applicant defend the City. It is expressly agreed that Applicant may select legal counsel providing the Applicant's defense and the City shall have the right to approve separate legal counsel providing the City's defense. The Applicant shall reimburse City for any attorneys' fees, costs and expenses directly and necessarily incurred by the City in the course of the defense. Applicant agrees that City will forward monthly invoices to Applicant for attorneys' fees, costs and expenses it has incurred related to its defense of any Action and Applicant agrees to timely payment within thirty (30) days of receipt of the invoice. Within fourteen (14) days of an Action being filed, Applicant agrees to post adequate security or a cash deposit with City in an amount to cover the City's estimated attorneys' fees, costs and expenses incurred by City in the course of

**ATTACHMENT A - EXHIBIT 1
CONDITIONS OF APPROVAL**

Project No.: Tentative Parcel Map No. 37717 (Planning Application No. 19-0068)

Applicant: Ms. Jean Weiler, Ann Sullivan Nursery School - APN: 380-050-001, 002, 005 & 006

TPM No. 37717 (Dir. Hearing Approval Date):

July 23, 2019

TPM No. 37717 (Expiration Date:)

July 23, 2022

Conditions of Approval

**Timing /
Implementation**

**Enforcement /
Monitoring**

**Verification (Date
and Signature)**

	the defense in order to ensure timely payment of the City's invoices. The amount of the security or cash deposit shall be determined by the City. City shall cooperate with Applicant in the defense of any Action.			
4.	Approval of <i>Tentative Parcel Map No. 37717</i> is subject to a 10-day appeal period. Any appeal of the Planning Director's decision must be made to the City Clerk (accompanied by an official appeal application and \$964.00 filing fee) no later than August 5, 2019 (by 5 pm). Any appeal submitted by the deadline will be reviewed by the Planning Commission in accordance Section 16.04.030.A of the Wildomar Municipal Code at a noticed public hearing.	August 5, 2019	City Clerk & Planning Department	
5.	Approval of <i>Tentative Parcel Map No. 37717</i> shall expire on July 23, 2022 (3 years after approval by the Planning Director) if the final map has not been approved by the City Council and recorded with the Riverside County Clerk. The Applicant may apply for an Extension of Time (EOT) in accordance with Section 16.12.240 of the Wildomar Municipal Code. Said extension of time application and required fee must be submitted to the Planning Department prior to the expiration date.	July 23, 2022	Planning Department	
6.	In accordance with Section 66020.d.1 of the Government Code, the Applicant has 90 days from project approval to file a protest of the imposition of fees, dedications, reservations, or other exactions being imposed on this project. Notice is hereby given to the Applicant that the 90-day appeal hereby begins with approval of this project.	October 23, 2019	Planning Department	

**ATTACHMENT A - EXHIBIT 1
CONDITIONS OF APPROVAL**

Project No.: Tentative Parcel Map No. 37717 (Planning Application No. 19-0068)

Applicant: Ms. Jean Weiler, Ann Sullivan Nursery School - APN: 380-050-001, 002, 005 & 006

TPM No. 37717 (Dir. Hearing Approval Date):

July 23, 2019

TPM No. 37717 (Expiration Date:)

July 23, 2022

Conditions of Approval

**Timing /
Implementation**

**Enforcement /
Monitoring**

**Verification (Date
and Signature)**

7.	Within 60 days of approval of the TPM No. 37717 (PA No. 19-0068) by the Planning Director, the Applicant shall pay any outstanding deposit account balances. Failure to pay the outstanding balance by the due date may result in delays in the submittal of final map, grading plans, improvement plans and/or building/construction plans.	Sept. 23, 2019	Planning Department	
8.	The project shall be subdivided in accordance with the Tentative Parcel Map No. 37717 (and the conditions contained herein) as approved by the Planning Director on July 9, 2019. If needed, the Applicant may request a minor change/revision to be reviewed by the Planning Commission in accordance with Sections 16.12.210 and/or 16.12.220 of the Wildomar Municipal Code.	Ongoing	Planning Department	

PUBLIC WORKS/ENGINEERING/BUILDING DEPARTMENT CONDITIONS

General Requirements / Standard Conditions

1.	The developer shall obtain City approval for any modifications or revisions to the approval of this project. Deviations not identified on the plans may not be approved by the City, potentially resulting in the need for the project to be redesigned. Amended entitlement approvals may be necessary as a result.	On-Going	Engineering Dept.	
2.	No grading shall be performed without the prior issuance of a grading permit by the City.	On-Going	Engineering Dept.	

**ATTACHMENT A - EXHIBIT 1
CONDITIONS OF APPROVAL**

Project No.: Tentative Parcel Map No. 37717 (Planning Application No. 19-0068)

Applicant: Ms. Jean Weiler, Ann Sullivan Nursery School - APN: 380-050-001, 002, 005 & 006

TPM No. 37717 (Dir. Hearing Approval Date):

July 23, 2019

TPM No. 37717 (Expiration Date:)

July 23, 2022

Conditions of Approval

**Timing /
Implementation**

**Enforcement /
Monitoring**

**Verification (Date
and Signature)**

3.	Written permission shall be obtained from the affected property owners allowing the proposed grading and/or facilities to be installed outside of the project boundaries.	On-Going	Engineering Dept.	
4.	The developer/owner or contractor shall apply for an Encroachment Permit for work performed within the public right of way. Compliance with current environmental regulations applies and additional studies and/or permits may be required.	On-Going	Public Works	
5.	The developer's contractor is required to submit for a haul route permit for the hauling of material to and from the project site. Said permit will include limitations of haul hours, number of loads per day and the posting of traffic control personnel at all approved entrances/exits onto public roads. Hauled material shall be to/from an approved site.	On-Going	Public Works	
6.	Storm water and non-storm water discharges from the project site shall be mitigated in conformance with the applicable Regional Water Quality Control Board permit(s) and/or site specific SWPPP prior to entering into the MS4s.	On-Going	Engineering Dept.	
7.	For commercial/industrial projects, the developer/applicant shall submit a Business Registration application to the city for approval. The Business Registration shall indicate that this business is required to submit a Stormwater Compliance Deposit to the City for ongoing Commercial/Industrial Inspection requirements of the City's MS4 permit (NPDES Inspection). The requirement for stormwater compliance deposits and NPDES inspections are recurring for the duration of the conditional use permit. The developer/applicant shall also provide to	On-Going	Engineering Dept.	

**ATTACHMENT A - EXHIBIT 1
CONDITIONS OF APPROVAL**

Project No.: Tentative Parcel Map No. 37717 (Planning Application No. 19-0068)

Applicant: Ms. Jean Weiler, Ann Sullivan Nursery School - APN: 380-050-001, 002, 005 & 006

TPM No. 37717 (Dir. Hearing Approval Date):

July 23, 2019

TPM No. 37717 (Expiration Date:)

July 23, 2022

Conditions of Approval

**Timing /
Implementation**

**Enforcement /
Monitoring**

**Verification (Date
and Signature)**

	the Planning Department, as part of the Business' Statement of Operations, a copy of the educational materials, business' handbook, training or similar documents describing the business' best management practices for storm water pollution prevention.			
8.	The developer/applicant shall provide all tenants/employees/homeowners with educational materials regarding Best Management Practices for Stormwater Pollution Prevention. Educational materials are available on the Riverside County Flood Control and Water Conservation District's website. .	On-Going	Engineering Dept.	
9.	The developer/owner/tenant shall comply with all applicable laws and regulations regarding the proper disposal of waste materials generated from the business.	On-Going	Engineering Dept.	
10.	The Developer shall dedicate, design and construct all improvements in accordance the City of Wildomar Road Improvement Standards & Specification, Improvement Plan Check Policies and Guidelines, as further conditioned herein and to the satisfaction of the City Engineer.	On-Going	Engineering Dept.	
11.	The Developer shall be responsible for all costs associated with off-site right-of-way and/or easement acquisition, including any costs associated with the eminent domain process, if necessary.	On-Going	Engineering Dept.	
12.	The 10 year storm flow shall be contained within the curb and the 100 year storm flow shall be contained within the street right of way. When either of these criteria is exceeded, additional drainage facilities shall	On-Going	Engineering Dept.	

**ATTACHMENT A - EXHIBIT 1
CONDITIONS OF APPROVAL**

Project No.: Tentative Parcel Map No. 37717 (Planning Application No. 19-0068)

Applicant: Ms. Jean Weiler, Ann Sullivan Nursery School - APN: 380-050-001, 002, 005 & 006

TPM No. 37717 (Dir. Hearing Approval Date):

July 23, 2019

TPM No. 37717 (Expiration Date:)

July 23, 2022

Conditions of Approval

**Timing /
Implementation**

**Enforcement /
Monitoring**

**Verification (Date
and Signature)**

	be installed. All lots shall be graded to drain to the adjacent street or an adequate outlet.			
13.	All grading shall conform to the California Building Code, including Appendix J, and all other relevant laws, rules, and regulations governing grading in the City of Wildomar. Prior to commencing any grading which includes 50 or more cubic yards, the developer shall obtain a grading permit from the Building Department.	On-Going	Engineering Dept.	
14.	All necessary measures to control dust shall be implemented by the developer during grading to the satisfaction of the City Engineer. A PM10 plan may be required at the time a grading permit is issued.	On-Going	Engineering Dept.	
15.	Graded slopes shall be limited to a maximum steepness ratio of 2:1 (horizontal to vertical) with surface drainage collection unless otherwise approved by the City Engineer. Contour grade to mimic natural slopes in the area.	On-Going	Engineering Dept.	
16.	Grading in excess of 199 cubic yards will require performance security to be posted with the City.	On-Going	Engineering Dept.	
17.	All retaining walls shall require a separate permit from the Building Department.	On-Going	Building Dept.	ALL PHASES
18.	Erosion control – landscape plans, required for manufactured slopes greater than 3 feet in vertical height, are to be signed by a registered landscape architect and bonded. The soils engineer shall review the erosion control plans for conformance with the Geotechnical Report's Findings and Recommendations. Erosion control shall be placed within	On-Going	Engineering Dept. Planning Dept.	

**ATTACHMENT A - EXHIBIT 1
CONDITIONS OF APPROVAL**

Project No.: Tentative Parcel Map No. 37717 (Planning Application No. 19-0068)

Applicant: Ms. Jean Weiler, Ann Sullivan Nursery School - APN: 380-050-001, 002, 005 & 006

TPM No. 37717 (Dir. Hearing Approval Date):

July 23, 2019

TPM No. 37717 (Expiration Date:)

July 23, 2022

Conditions of Approval

**Timing /
Implementation**

**Enforcement /
Monitoring**

**Verification (Date
and Signature)**

	30 days of meeting final grades to minimize erosion and to ensure slope coverage prior to the rainy season. The Developer shall plant & irrigate all manufactured slopes steeper than a 4:1 (horizontal to vertical) ratio and 3 feet or greater in vertical height with soil stabilizers and ground cover; slopes 15 feet or greater in vertical height shall be planted with additional shrubs or trees or as approved by the City Engineer and City Planner.			
19.	Should this project lie within any assessment/benefit district, the project proponent shall, prior to acceptance of improvements, make application for and pay for their reapportionment of the assessments or pay the unit fees in the benefit district unless said fees are otherwise deferred or covered under the City's Community Facility District (CFD Services).	On-Going	Engineering Dept.	
20.	The developer shall annex into the City's Community Facility District (CFD Services) and pay associated costs for annexation. Should this project lie within any assessment/benefit district that duplicates the services to be covered under CFD Services then the developer shall de-annex from said assessment/benefit district.	Prior to subdivision and/or improvement plan approval of Parcel 1	Engineering Dept.	
21.	The developer shall design and construct all driveways in accordance with the City of Wildomar Improvement Standards.	On-Going	Engineering Dept.	
22.	The improvement plans must provide tapers to existing improvements based on design speed, offset, profile and sight distance extending a minimum of 300 feet beyond the project boundaries at a grade and alignment as approved by the City Engineer.	On-Going	Engineering Dept.	

**ATTACHMENT A - EXHIBIT 1
CONDITIONS OF APPROVAL**

Project No.: Tentative Parcel Map No. 37717 (Planning Application No. 19-0068)

Applicant: Ms. Jean Weiler, Ann Sullivan Nursery School - APN: 380-050-001, 002, 005 & 006

TPM No. 37717 (Dir. Hearing Approval Date):

July 23, 2019

TPM No. 37717 (Expiration Date:)

July 23, 2022

Conditions of Approval

**Timing /
Implementation**

**Enforcement /
Monitoring**

**Verification (Date
and Signature)**

23.	Above-ground utilities shall be undergrounded by the developer in accordance with City of Wildomar Municipal Code 16.04.010. The undergrounding of utilities shall be reflected on the project improvement plans.	On-Going	Engineering Dept.	
24.	Improvement Plans for underground utilities (eg. Water, sewer, electrical, telecommunications, etc.) to be placed in public right of way or easement that will be owned and maintained by other entities shall be reviewed by the City prior to Utility Agency approval. The City shall have a place on the Title Sheet to accept the plans with a statement "The city's acceptance is limited to the placement of utilities relative to public infrastructure clearances, uses and future plans within the right of way." The plans shall be attached to a city Encroachment Permit.	On-Going	Engineering Dept.	
25.	All flood control plans to be reviewed by the City or the Riverside County Flood Control District (RCFCD) shall be submitted through the City of Wildomar, unless otherwise directed by the City Engineer. For projects requiring RCFCD review the developer shall pay the appropriate fees to RCFCD.	On-Going	Engineering Dept.	
<u>Prior to the Issuance of Grading Permits</u>				
26.	The developer shall submit a geotechnical soils reports to the City Engineer for review and approval prior to issuance of grading permit. The findings and recommendations shall reflect current conditions and the report shall be no older than one (1) year. All grading shall be in	Prior to Issuance of a Grading Permit	Engineering Dept.	

**ATTACHMENT A - EXHIBIT 1
CONDITIONS OF APPROVAL**

Project No.: Tentative Parcel Map No. 37717 (Planning Application No. 19-0068)

Applicant: Ms. Jean Weiler, Ann Sullivan Nursery School - APN: 380-050-001, 002, 005 & 006

TPM No. 37717 (Dir. Hearing Approval Date):

July 23, 2019

TPM No. 37717 (Expiration Date:)

July 23, 2022

Conditions of Approval

**Timing /
Implementation**

**Enforcement /
Monitoring**

**Verification (Date
and Signature)**

	conformance with the recommendations of the geotechnical/soils reports as approved by City of Wildomar.			
27.	The developer shall obtain any and all easements and/or permissions necessary to perform the grading required for the project. A notarized letter of permission from all affected property owners or easement holders, or encroachment permit, is required for all off-site grading.	Prior to Issuance of a Grading Permit	Engineering Dept.	
28.	The project specific SWPPP and an Erosion/Sediment Control plan shall be approved by the City Engineer.	Prior to Issuance of a Grading Permit	Engineering Dept.	
29.	The Developer shall provide the Engineering Department evidence of compliance with the National Pollutant Discharge Elimination System (NPDES); obtain a construction permit from the State Water Resource Control Board (SWRRCB); and, reference the WDID number on the improvement/grading plans.	Prior to Issuance of a Grading Permit	Engineering Dept.	
30.	The developer shall have obtained approval for the import/export location from the City of Wildomar. Additionally, if either location was not previously approved by an Environmental Assessment, prior to issuing a grading permit, a Grading Environmental Assessment shall be submitted to the Planning Director for review and comment and to the City Engineer for approval.	Prior to Issuance of a Grading Permit	Engineering Dept.	
31.	A licensed engineer shall prepare and submit a Water Quality Management Plan (WQMP) Applicability Checklist; determine if a WQMP is applicable for this project; and, sign and stamp the WQMP checklist with their license seal.	Prior to Issuance of a Grading Permit	Engineering Dept.	

**ATTACHMENT A - EXHIBIT 1
CONDITIONS OF APPROVAL**

Project No.: Tentative Parcel Map No. 37717 (Planning Application No. 19-0068)

Applicant: Ms. Jean Weiler, Ann Sullivan Nursery School - APN: 380-050-001, 002, 005 & 006

TPM No. 37717 (Dir. Hearing Approval Date):

July 23, 2019

TPM No. 37717 (Expiration Date:)

July 23, 2022

Conditions of Approval

**Timing /
Implementation**

**Enforcement /
Monitoring**

**Verification (Date
and Signature)**

32.	<p>If the WQMP is required, an approved Final Water Quality Management Plan (WQMP), in conformance with the requirements of the San Diego and/or Santa Ana Regional Water Quality Control Board. Applicant shall confirm the watershed requirements relative to their project location shall be approved by the City Engineer prior to issuance of a grading permit. All stormwater quality treatment devices shall be located outside of the ultimate public right of way. The developer shall design the stormwater quality treatment devices to accommodate all project runoff, ensuring post-construction flows and volumes do not exceed pre-construction levels, in accordance with City of Wildomar's Hydrology Manual, Stormwater Quality Best Management Practice Design Handbook, Improvement Standards, and to the satisfaction of the City Engineer. These BMPs shall be consistent with the Final WQMP and installed and maintained to the satisfaction of the City Engineer. The project shall use the following hydromodification criteria for the project site: "The runoff flow rate, volume, velocity, and duration for the post development condition of the Priority Development Project do not exceed the pre-development (i.e. naturally occurring) condition for the 2 year, 24 hour and 10 year, 24 hour rainfall events. This condition must be substantiated by hydrologic modelling acceptable to City of Wildomar."</p>	Prior to Issuance of a Grading Permit	Engineering Dept.	
33.	<p>If the project location is within the Santa Ana River Watershed: Prior to the issuance of a grading permit, the developer is to provide the appropriate documentation that will allow this project a waiver for mitigation volume related to the Lake Elsinore sub watershed of the Santa Ana Watershed. Please note the City is not a permittee in the</p>	Prior to Issuance of a Grading Permit	Engineering Dept.	ALL PHASES

**ATTACHMENT A - EXHIBIT 1
CONDITIONS OF APPROVAL**

Project No.: Tentative Parcel Map No. 37717 (Planning Application No. 19-0068)

Applicant: Ms. Jean Weiler, Ann Sullivan Nursery School - APN: 380-050-001, 002, 005 & 006

TPM No. 37717 (Dir. Hearing Approval Date):

July 23, 2019

TPM No. 37717 (Expiration Date:)

July 23, 2022

Conditions of Approval

**Timing /
Implementation**

**Enforcement /
Monitoring**

**Verification (Date
and Signature)**

	MS4 permit for the Santa Ana River Watershed (Lake Elsinore) and is governed only by the MS4 permit for the Santa Margarita Watershed, therefore the Applicant needs to provide evidence that this waiver has been approved by the Santa Ana Regional Water Quality Control Board. Otherwise volume has to be addressed.			
34.	A Grading Agreement and a Storm Water Management Facilities Agreement shall be approved by the City Engineer and/or City Council.	Prior to Issuance of a Grading Permit	Engineering Dept.	
35.	The developer shall prepare and submit a comprehensive drainage study and plan that includes, but is not limited to: definition with mapping of the existing watersheds; a detailed pre- and post-project hydrologic and hydraulic analysis of the project and project impacts; definition of the local controlling 100-year frequency water levels existing and with project; the proposed method of flow conveyance to mitigate the potential project impacts with adequate supporting calculations; any proposed improvements to mitigate the impacts of increased runoff from the project and any change in runoff; including quality, quantity, volume, and duration in accordance with City of Wildomar's Hydrology Manual, Improvement Standards, and to the satisfaction of the City Engineer. Specifically, the study will: <ul style="list-style-type: none"> d. Analyze the detention basin drainage area for a project using the Rational Method 100-year storm event for the pre-project and post-project. e. Analyze 4 hydrographs for the detention basin drainage area for a project using the Unit Hydrograph 100-year storm event for the 	Prior to Issuance of a Grading Permit	Engineering Dept.	

**ATTACHMENT A - EXHIBIT 1
CONDITIONS OF APPROVAL**

Project No.: Tentative Parcel Map No. 37717 (Planning Application No. 19-0068)

Applicant: Ms. Jean Weiler, Ann Sullivan Nursery School - APN: 380-050-001, 002, 005 & 006

TPM No. 37717 (Dir. Hearing Approval Date):

July 23, 2019

TPM No. 37717 (Expiration Date:)

July 23, 2022

Conditions of Approval

**Timing /
Implementation**

**Enforcement /
Monitoring**

**Verification (Date
and Signature)**

	<p>1-hour, 3-hour, 6-hour, and 24-hour storm durations for post-project condition.</p> <p>f. Using the Unit Hydrographs determine which duration provides the highest flow rate. Adjust parameters such as lag time, flow line roughness coefficient or other parameters to calibrate Unit Hydrograph model to provide results similar to the Rational Method.</p> <p>g. Using the calibrated Unit Hydrograph for the detention basin drainage area perform basin routing analysis to demonstrate that the outflow is less than the pre-project Rational Method flow rate.</p>			
36.	The developer shall show all easements per the Title Report to the satisfaction of Public Works. Any conflict with existing easements resulting in the site being redesigned potentially requires a minor change or amendment approval by Planning Commission.	Prior to the 1st Improvement Plan submittal	Engineering Dept.	
<u>Prior to Recordation of Final Map</u>				
37.	Improvement plans shall be prepared, processed, and approved. Construct the improvements; or execute an Improvement Agreement and Improvement Security. This condition shall be in conformance with local regulations and the Subdivision Map Act.	Prior to subdivision and/or improvement plan approval of Parcel 1	Engineering Dept.	ALL PHASES
38.	The developer shall dedicate, design and construct streetlights in accordance with the City of Wildomar Road Improvement Standards &	Prior to subdivision and/or improvement plan	Engineering Dept.	

**ATTACHMENT A - EXHIBIT 1
CONDITIONS OF APPROVAL**

Project No.: Tentative Parcel Map No. 37717 (Planning Application No. 19-0068)

Applicant: Ms. Jean Weiler, Ann Sullivan Nursery School - APN: 380-050-001, 002, 005 & 006

TPM No. 37717 (Dir. Hearing Approval Date):

July 23, 2019

TPM No. 37717 (Expiration Date:)

July 23, 2022

Conditions of Approval

**Timing /
Implementation**

**Enforcement /
Monitoring**

**Verification (Date
and Signature)**

	Specification, Improvement Plan Check Policies and Guidelines, City Ordinances and to the satisfaction of the City Engineer.	approval of Parcel 1		
39.	The developer shall dedicate a public utility easement adjacent to all public and private streets for overhead and/or underground facilities and appurtenances to the satisfaction of the City Engineer.	Prior to subdivision and/or improvement plan approval of Parcel 1	Engineering Dept.	
40.	The developer shall submit landscaping and irrigation plans within the public right-of-way to the Planning Department. These plans shall include water usage calculations, estimate of irrigation and the location of all existing trees that will remain. All plans and calculations shall be designed and calculated per the City of Wildomar Road Improvement Standards & Specification, Improvement Plan Check Policies and Guidelines, City Codes and to the satisfaction of the City Engineer.	Prior to subdivision and/or improvement plan approval of Parcel 1	Engineering Dept. Planning Dept.	
41.	The developer shall execute a maintenance agreement for the stormwater quality control treatment device to the satisfaction of the City Engineer.	Prior to subdivision and/or improvement plan approval of Parcel 1	Engineering Dept.	
<u>Prior to Issuance of a Building Permit</u>				
42.	The developer/owner shall obtain a grading permit and/or approval to construct from the City Engineer.	Prior to Issuance of a Building Permit	Building Dept. Engineering Dept.	

**ATTACHMENT A - EXHIBIT 1
CONDITIONS OF APPROVAL**

Project No.: Tentative Parcel Map No. 37717 (Planning Application No. 19-0068)

Applicant: Ms. Jean Weiler, Ann Sullivan Nursery School - APN: 380-050-001, 002, 005 & 006

TPM No. 37717 (Dir. Hearing Approval Date):

July 23, 2019

TPM No. 37717 (Expiration Date:)

July 23, 2022

Conditions of Approval

**Timing /
Implementation**

**Enforcement /
Monitoring**

**Verification (Date
and Signature)**

43.	Improvement plans shall be approved by the City Engineer and all improvements to be constructed shall be secured by the Developer.	Prior to Issuance of a Building Permit	Building Dept. Engineering Dept.	
44.	The developer shall provide will serve letters from the appropriate water and sewer agencies.	Prior to Issuance of a Building Permit	Building Dept.	
45.	The developer shall provide approval letter from Fire Department for fire water service	Prior to Issuance of a Building Permit	Building Dept. Fire Dept.	
46.	The developer shall install streetlights in accordance with the City of Wildomar Road Improvement Standards & Specification, Improvement Plan Check Policies and Guidelines, City Ordinances and to the satisfaction of the City Engineer.	Prior to Issuance of a Building Permit	Building Dept. Public Works Dept.	
47.	The developer shall install all street name signs at intersections adjacent to the project, public or private and/or replace street name signs in accordance with the City of Wildomar Standard Details and to the satisfaction of the City Engineer.	Prior to Issuance of a Building Permit	Public Works Dept.	
48.	The developer shall annex into the CFD Services District to offset development related costs for maintenance and services.	Prior to Issuance of a Building Permit	Engineering Dept.	
49.	The developer/applicant shall demonstrate that all development related fees, impact fees, and mitigation fees have been satisfactorily paid.	Prior to Issuance of a Building Permit	Building Dept.	
50.	The developer shall pay the appropriate impact mitigation fee to the Riverside County Flood Control and Water Conservation District and provide the City receipt of payment.	Prior to Issuance of a Building Permit	Building Dept.	

**ATTACHMENT A - EXHIBIT 1
CONDITIONS OF APPROVAL**

Project No.: Tentative Parcel Map No. 37717 (Planning Application No. 19-0068)

Applicant: Ms. Jean Weiler, Ann Sullivan Nursery School - APN: 380-050-001, 002, 005 & 006

TPM No. 37717 (Dir. Hearing Approval Date):

July 23, 2019

TPM No. 37717 (Expiration Date:)

July 23, 2022

Conditions of Approval

**Timing /
Implementation**

**Enforcement /
Monitoring**

**Verification (Date
and Signature)**

51.	The developer shall pay all necessary impact and mitigation fees required. These fees include, but are not limited to, fees associated with Transportation Uniform Mitigation Fee (TUMF), Quimby (parkland in-lieu) Fee, and City Development Impact Fees.	Prior to Issuance of a Building Permit or Certificate of Occupancy	Building Dept.	
52.	The developer shall construct the stormwater quality treatment devices to accommodate all project runoff from in accordance with City of Wildomar's Hydrology Manual, Stormwater Quality Best Management Practice Design Handbook, Improvement Standards, and to the satisfaction of the City Engineer. All stormwater quality treatment devices shall be constructed outside of the ultimate public right of way.	Prior to Issuance of a Building Permit	Engineering Dept.	

Final Map – Project Specific

53.	The developer shall dedicate, the northwesterly right of way of Palomar Road, measured, 56' from the approved centerline along the property frontage. Right of way will be based on a modified arterial, Standard No. 92, in accordance with the City of Wildomar Improvement Standards & Specifications and to the satisfaction of the City Engineer.	At Recordation of Final Map	Engineering Dept.	
-----	--	-----------------------------	-------------------	--

RIVERSIDE COUNTY FIRE DEPARTMENT

General Conditions – Parcel Map No. 37717

1.	Fire flow and hydrants: the applicant or developer shall provide fire hydrants in accordance with the following: <ul style="list-style-type: none"> Prior to placing any combustibles on site, provide an approved water source for firefighting purposes. 	On-Going	Fire Department	
----	---	----------	-----------------	--

**ATTACHMENT A - EXHIBIT 1
CONDITIONS OF APPROVAL**

Project No.: Tentative Parcel Map No. 37717 (Planning Application No. 19-0068)

Applicant: Ms. Jean Weiler, Ann Sullivan Nursery School - APN: 380-050-001, 002, 005 & 006

TPM No. 37717 (Dir. Hearing Approval Date):

July 23, 2019

TPM No. 37717 (Expiration Date:)

July 23, 2022

Conditions of Approval

**Timing /
Implementation**

**Enforcement /
Monitoring**

**Verification (Date
and Signature)**

	<ul style="list-style-type: none"> Prior to building permit issuance, submit plans to the water district for a water system capable of delivering fire flow as required by the California Fire Code and Fire Department standards. Fire hydrants shall be spaced in accordance with the California Fire Code. 			
2.	Prior to building permit issuance, install the approved water system, approved access roads, and contact the Fire Department for a verification inspection.	Prior to Issuance of Building Permit	Fire Department	
3.	Emergency access roads must meet fire department standards at the time of building permit application. Current standards require minimum 24-foot wide roads for buildings less than 30 feet tall, and minimum 30-foot wide roads for buildings 30 feet tall and higher. Roads must be capable of supporting at least 80,000 pounds.	Prior to Issuance of Building Permit	Fire Department	

END

ATTACHMENT B

Tentative Parcel Map No. 37717 Exhibit

TENTATIVE PARCEL MAP NO. 37717

IN THE CITY OF WILDOMAR, COUNTY OF RIVERSIDE, STATE OF CALIFORNIA

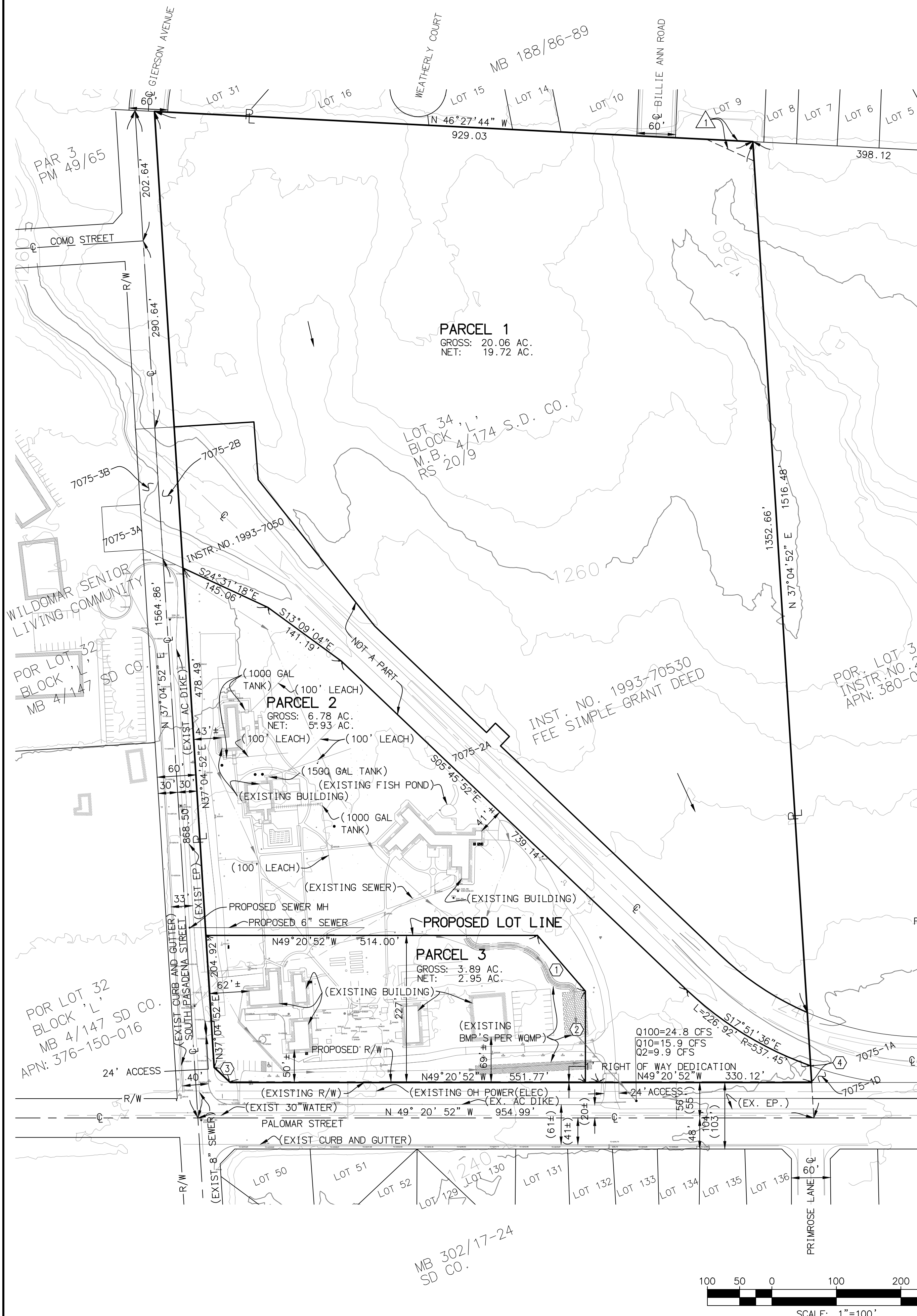

APPLICANT & OWNER:
 CAFH ORDER OF WILDOMAR, INC.
 JEANNE WEILER, PRESIDENT
 21776 PALOMAR STREET
 WILDOMAR, CA 92595
 ATTN: JEANNE WEILER
 EMAIL: CAFHOF@ANNESULLIVANSCHOOL.COM
 TEL: (951) 599-8052

REPRESENTATIVE & PREPARER:
 TEMECULA ENGINEERING CONSULTANTS, INC.
 STANLEY D. HEATON, PE
 29377 RANCHO CALIFORNIA RD., SUITE 202
 TEMECULA, CALIFORNIA 92591
 EMAIL: STAN.HEATON@VERIZON.NET
 TEL: (951) 676-1018
 FAX: (951) 676-2294
 DATE PREPARED: FEBRUARY 11, 2019

ASSESSORS PARCEL NUMBER
 380-050-001, -002, -005, -006

LEGAL DESCRIPTION:
 REAL PROPERTY IN THE CITY OF WILDOMAR, COUNTY OF RIVERSIDE, STATE OF CALIFORNIA, DESCRIBED AS FOLLOWS:
 THE NORTHWESTERLY THIRTY-THREE(33) ACRES OF LOT 34 IN BLOCK L AS SHOWN BY MAP OF BLOCKS K, L AND M OF ELSINORE, ON FILE IN BOOK 4, PAGE 174 OF MAPS, SAN DIEGO COUNTY RECORDS.

EXCEPT THE SOUTHWEST 25.00 FEET OF SAID LAND GRANTED TO THE COUNTY OF RIVERSIDE BY DEED RECORDED APRIL 24, 1975 AS INSTRUMENT NO. 47026.
 ALSO EXCEPTING THAT PORTION THEREOF GRANTED TO RIVERSIDE COUNTY FLOOD CONTROL AND WATER CONSERVATION DISTRICT BY DEED RECORDED FEBRUARY 24, 1993 AS INSTRUMENT NO. 70530, OFFICIAL RECORDS OF SAID COUNTY.

BASIS OF BEARINGS:
 BASIS OF BEARING FOR THIS CALIFORNIA SURVEY IS THE STATE PLANE COORDINATE SYSTEM ZONE 6, N.A.D., 1927, BASED UPON TRI. STATIONS "ELSINORE" AND "WILDOMAR." PER RECORD OF SURVEY 90/90-91

LINE AND CURVE DATA			
#	BEARING/DELTA	RADIUS	LENGTH
1	S00°07'41"E	--	114.00'
2	S40°39'08"W	--	140.68'
3	N06°08'00"W	--	32.82'
4	S37°04'52"W	--	25.04'

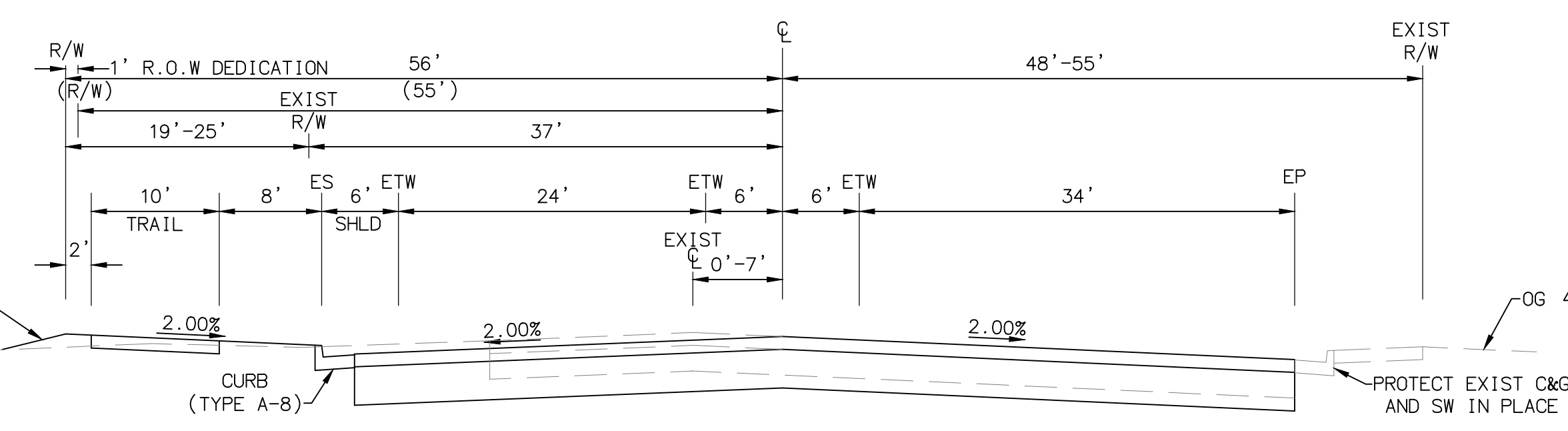

PALOMAR STREET
 STA: 97+25 TO STA: 111+02
 N.T.S.

LEGEND & ABBREVIATION:
 R/W RIGHT OF WAY
 C CENTERLINE
 P PROPERTY LINE
 H.P. HIGH POINT
 L.P. LOW POINT
 G.B. GRADE BREAK
 F.S. FINISHED SURFACE
 F.G. FINISHED GRADE
 F FLOWLINE
 E ACREAGE
 AC. ACREAGE
 2:1 SLOPE (UNLESS OTHERWISE NOTED)
 (1900) EXISTING CONTOUR
 DRAINAGE FLOW

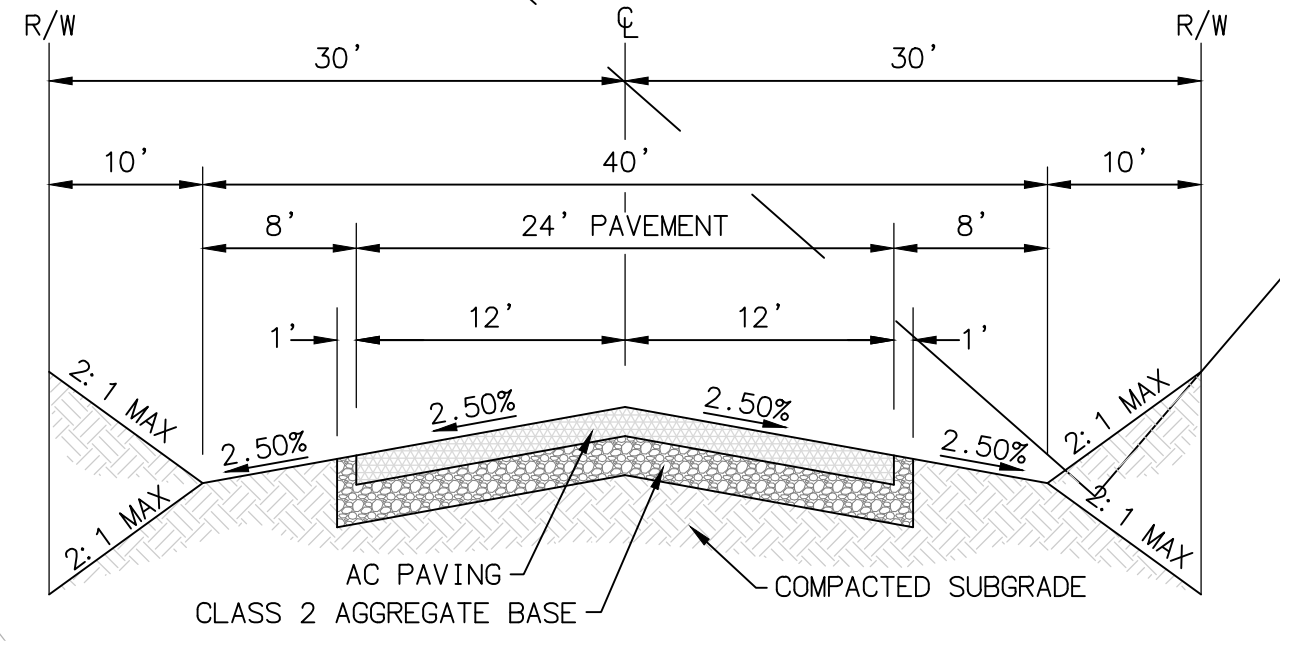

SOUTH PASADENA STREET
 RESIDENTIAL RURAL ROAD (TYPICAL)
 N.T.S.

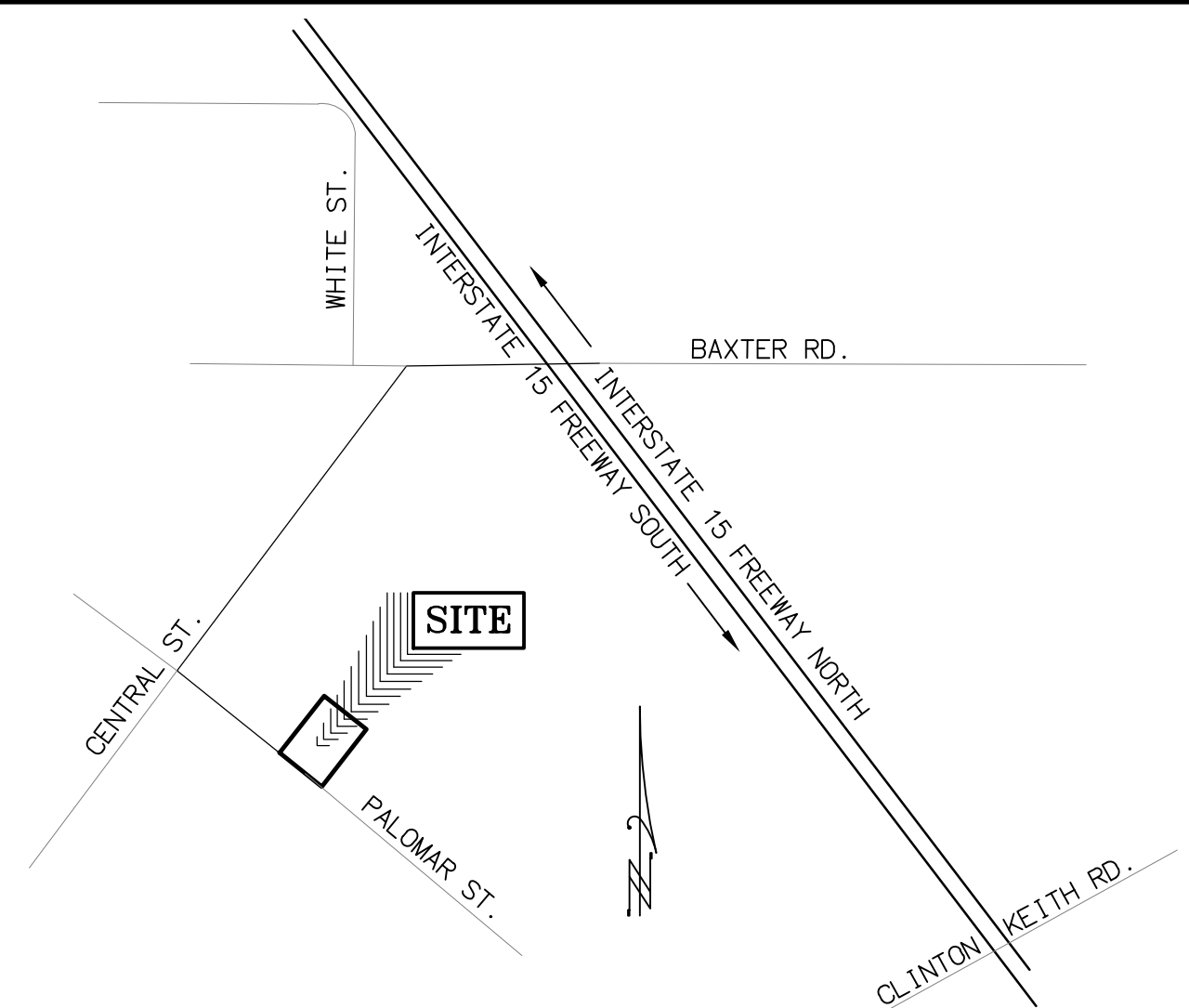

VICINITY MAP
 NOT TO SCALE
THOMAS BROTHERS GUIDE
 SEC. 35, T. 6S, R. 4W
 POR. PROTRACTED SEC. 2, T. 7S, R. 4W
 2006 EDITION

BENCHMARK:
 USC & GS BRASS DISK, UP 0.33' STAMPED ELSINORE 1939.
 N524126.48 E1667366.10

ACREAGE:
 GROSS 30.74± ACRES
 NET 28.60± ACRES

EXISTING ZONING
 RURAL-RESIDENTIAL

EXISTING LAND USE
 PRESCHOOL AND KINDERGARTEN

PROPOSED ZONING
 NO CHANGE

PROPOSED LAND USE
 RESIDENTIAL (NOTHING PROPOSED WITH THIS PARCEL MAP)

SPECIFIC PLAN
 NOT IN A SPECIFIC PLAN AREA

UTILITIES:
 ELECTRIC SOUTHERN CALIFORNIA EDISON
 GAS SOUTHERN CALIFORNIA GAS
 SEWER ELSINORE VALLEY MUNICIPAL WATER DISTRICT
 WATER ELSINORE VALLEY WATER DISTRICT
 TELEPHONE VERIZON

SCHOOL DISTRICT
 LAKE ELSINORE UNIFIED SCHOOL DISTRICT

SOURCE OF TOPOGRAPHY
 RIVERSIDE COUNTY FLOOD CONTROL 2019

CONTIGUOUS OWNERSHIP
 THIS TENTATIVE MAP INCLUDES THE ENTIRE CONTIGUOUS OWNERSHIP OF THE LAND DIVIDER.

GEOTECHNICAL INFORMATION:
 THIS LAND IS NOT SUBJECT TO LIQUEFACTION, OR OTHER GEOLOGIC HAZARDS, AND IS NOT WITHIN A SPECIAL STUDIES ZONE.

FLOOD INFORMATION AND DRAINAGE:
 THE PERPETUAL FLOOD CONTROL AND DRAINAGE EASEMENT LYING WITHIN LOT 34, BLOCK "L" OF THE MAP OF BLOCKS K, L & M ELSINORE CAL. AS SHOWN BY MAP ON FILE IN BOOK 4 OF MAPS AT PAGE 174, RECORDS OF SAN DIEGO COUNTY, CALIFORNIA, LYING WITHIN SECTION 35, TOWNSHIP 6 SOUTH, RANGE 4 WEST, SAN BERNARDINO MERIDIAN, IS HEREBY ACCEPTED BY THE CITY OF WILDOMAR, AS ORDERED BY THE CITY COUNCIL OF THE CITY OF WILDOMAR ON SEPTEMBER 9, 2015.

EASEMENT NOTES:
 THE FOLLOWING ITEMS ARE REFERENCED IN A TITLE REPORT PREPARED BY FIRST AMERICAN TITLE COMPANY AS ORDER NO. NHSC-5854690
 A DRAINAGE EASEMENT OVER A PORTION OF LOT 34 CONVEYED TO THE RIVERSIDE COUNTY FLOOD CONTROL AND WATER CONSERVATION DISTRICT RECORDER NOV. 15, 2017 INSTR. NO. 2017-0479088

TEC TEMECULA ENGINEERING CONSULTANTS, INC.
 LAND PLANNING, CIVIL ENGINEERING, CONSTRUCTION CONSULTANTS
 29377 RANCHO CALIF. RD., SUITE 202, TEMECULA, CA 92591
 * TELEPHONE 951-676-1018 * FACSIMILE 951-676-2294 *
 DATE: 04/10/2019 JOB No. 11116-1

P:\TEC\1100's\1116-1\DWG\TPM\1116-1_TENTATIVE_PARCEL_MAP.dwg, 4/11/2019 11:17:20 AM, DWG To PDF.pc